



# 12 CONSIDERATIONS FOR THERMAL INFRARED CAMERA LENS SELECTION



# OVERVIEW

When developing a solution that requires a thermal imager, or infrared (IR) camera, engineers, procurement agents, and program managers must consider many factors. Application, waveband, minimum resolution, pixel size, protective housing, and ability to scale production are just a few. One element that will impact many of these decisions is the IR camera lens.

USE THIS GUIDE AS A REFRESHER ON HOW TO GO ABOUT SELECTING THE OPTIMAL LENS FOR YOUR THERMAL IMAGING SOLUTION.

- 1 Waveband determines lens materials.
- 2 The image size must have a diameter equal to, or larger than, the diagonal of the array.
- 3 The lens should be mounted to account for the back working distance and to create an image at the focal plane array location.
- 4 As the Effective Focal Length or EFL increases, the field of view (FOV) narrows.
- 5 The lower the f number of a lens, the larger the optics will be, which means more energy is transferred to the array.
- 6 Depth of field is determined by using the closest and the farthest objects that appear to be in focus.
- 7 Modulation Transfer Function (MTF) measurement, distortion, and spot size are three standard characteristics to consider for lens performance as it pertains to image quality.
- 8 The transmission value of an IR camera lens is the level of energy that passes through the lens over the designed waveband.
- 9 Passive athermalization is most desirable for small systems where size and weight are a factor while active athermalization makes more sense for larger systems where a motor will weigh and cost less than adding the optical elements for passive athermalization.
- 10 Proper mounting is critical to ensure that the lens is in position for optimal performance.
- 11 There are three primary phases of production—engineering, manufacturing, and testing—that can take up to six months.
- 12 Silicon and Germanium are the most common lens materials. Even though Silicon is much less expensive, that does not always correlate directly with production costs.

# 1 WAVEBAND AND LENS MATERIALS

The three common wavebands covered by IR cameras are near or short-wave, mid-wave, and longwave. Some applications may require an IR camera to function across multiple wavebands (e.g., Dual band, 3rd Gen, and SeeSpot), but most applications require waveband specialization for each thermal imager. Lens materials must be selected based on key properties, such as index of refraction, to optimize performance.

TABLE 1:

WAVEBANDS AND LENS MATERIALS				
	WAVELENGTH (UM)	LENS MATERIALS	INDEX OF REFRACTION	LENS COUNTS
SWIR	0.9-2.5	ZnSe, ZnS, CaF2, chalcogenides, MgF2, BaF2, GaAs	Low	Typically High - Including cemented doublets or triplets
MWIR	3 - 5	Si, Ge, ZnSe, ZnS, chalcogenides, CaF2, MgF2, BaF2, GaAs	Low to Mid	Mid-Range - Can use diffractive and aspheric surfaces to reduce lens count
LWIR	8 - 14	Ge, ZnSe, chalcogenides	High	Few Elements Required - Diffractive and aspheric surfaces are common

# 2 IMAGE SIZE

The lens will need to create an image that will fill the focal plane array, or detector, of the IR camera. These arrays are rectangular or square in shape, but a lens creates a circular image at the focal plane. It must create an image that has a diameter equal to, or larger than, the diagonal of the array. If the image does not fill the detector area, the resulting effect is commonly referred to as vignetting. This will appear as fuzzy, gray, or darkened corners and/or edges of the image, depending on the severity that the lens vignettes.

The only exception to this rule is when dealing with fish-eye lenses, which create a hemispheric image within the dimensions of the focal plane array. If the diagonal of the array in the IR camera is not documented, it can be calculated using basic trigonometry (number of pixels and the pixel pitch). For example, a 320 x 240 pixel sensor with a 50-µm pitch equates to a 20-mm diagonal.

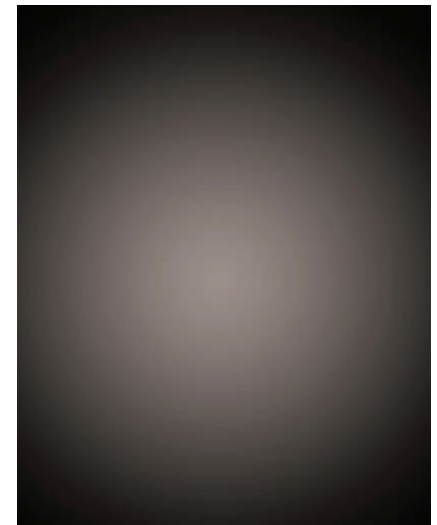

Figure 1: Image with Vignetting

$$\text{LENGTH OF FPA} = \# \text{ OF HORIZONTAL PIXELS} \times \text{PIXEL PITCH} = L$$

$$\text{WIDTH OF FPA} = \# \text{ OF VERTICAL PIXELS} \times \text{PIXEL PITCH} = W$$

$$\sqrt{L^2 + W^2} = \text{IMAGE CIRCLE DIAMETER}$$

### 3 BACK WORKING DISTANCE

The back working distance is the physical distance from the back of the lens housing to the focal plane array. The lens should be mounted so that it creates an image at the focal plane array location in the IR camera. Generally, IR cameras that require something between the lens and the array (i.e., dewar window and filters), will dictate the use of a lens with a longer back working distance. In some cases, it is possible to reduce the size of the lens by minimizing this distance, so it can be advantageous to be as close as possible to the array. For example, start a focal point and draw two lines extending out  $30^\circ$  apart to represent the field of view (FOV). The lens must capture both lines, so the further away from the focal point, the larger the lens needed.

Back working distance can allow for some flexibility if there are limitations on lens availability. An IR camera with a short back working distance can accommodate a lens with a longer back working distance by the use of an adapter or spacer. For example, an IR imager requiring a minimum distance of 10 mm can be fitted with a lens that has a back working distance of 30 mm employing a 20-mm spacer. However, the reverse is not possible. A lens that images at a distance of 10 mm cannot be properly positioned on an IR camera that needs a minimum distance of 30 mm.

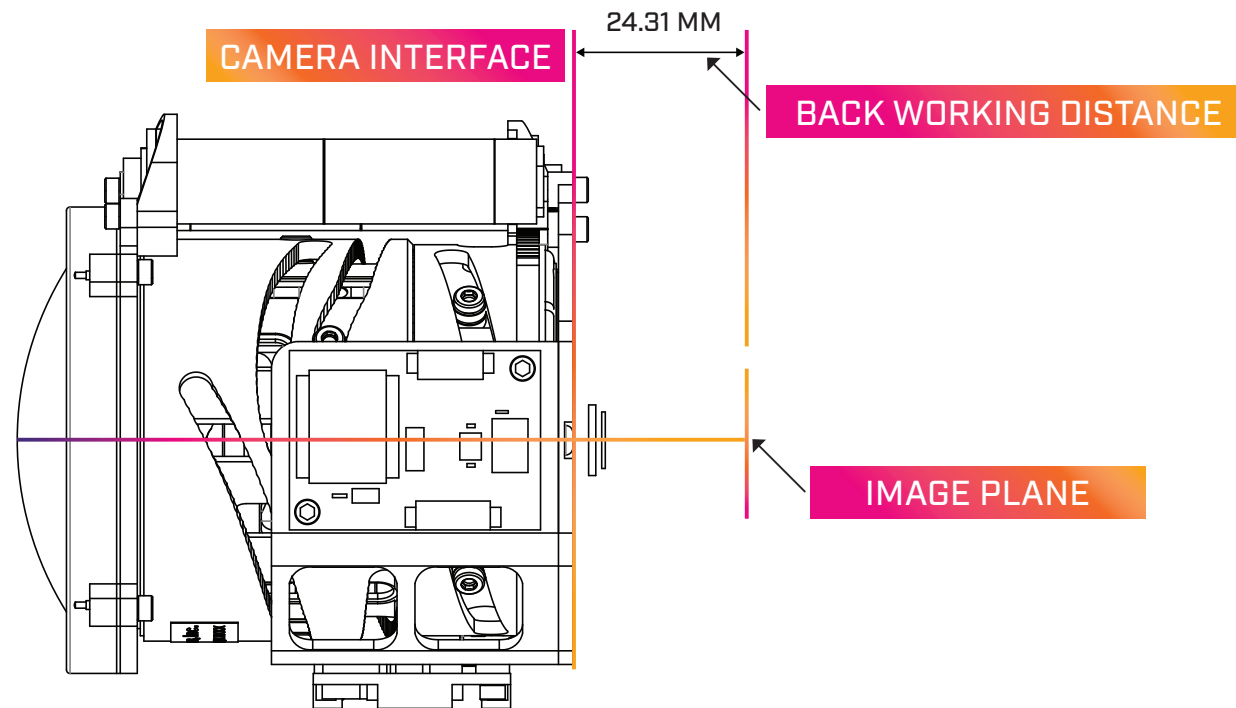

Figure 2: Back Working Distance

## 4 FOCAL LENGTH AND FIELD OF VIEW

Lenses are commonly identified by their focal length, sometimes referred to as effective focal length (EFL). As the focal length increases, the field of view (FOV) for that lens will be narrower. Conversely, as the focal length decreases, the FOV widens.

TABLE 2:

MANUFACTURERS ALSO CATEGORIZE LENSES BASED ON THEIR FOCAL LENGTHS.

NAME	DESCRIPTION	EXAMPLE USE
Normal	Lens creates an image close to what can be viewed by the human eye	Heat loss from a building
Telephoto	Lens physical size is shorter than their EFL	Persistent surveillance
Wide Angle	Lens produces a scene more spacious than normal vision	Sky mapping
Fisheye	Lenses with a field of view greater than 150°	Sky mapping
Multifield	Lens designed to switch between two or more focal lengths	Search and rescue
Continuous Zoom	Lens remains in focus anywhere between two boundary focal lengths	Border surveillance

!

$$EFL = \frac{1}{2} [FPA \text{ SIZE}] / \tan [ \frac{1}{2} \text{FOV} ]$$

It is important to know whether a lens is specified by the horizontal or vertical field of view. The horizontal number will help identify the angle that spans the width of the focal plane array, while the vertical field of view gives the angle spanning the height of the array. The same formula can be used to calculate horizontal and vertical field of view by substituting the applicable array measurement.

## 5 THE f NUMBER

In an IR camera, the f number of a lens dictates how much energy is transferred onto a focal plane array. The lower the f number of a lens, the larger the optics will be, which means more energy is transferred to the array. A lower f number creates a sharper image. Depending upon the application, such as in unmanned aerial vehicles (UAVs), this could be an area to make trade-offs to minimize lens size and weight. The f number is also referred to as the speed of the lens. For example, an f/2.3 lens may be considered faster than an f/4.0 lens.

The f number also dictates aperture size—if applicable. Apertures are more common in cooled MWIR cameras but do appear in some uncooled LWIR models. Located between the lens and focal plane array, an aperture functions as a shield to block unwanted radiation from reaching the array. The optimal lens used on these types of IR cameras should match the required f number at the proper aperture or pupil location, although a faster lens could be used.

When cameras have no aperture, there is much more flexibility in the f number chosen for the lens. However, these are typically uncooled LWIR cameras and are generally less sensitive to energy.

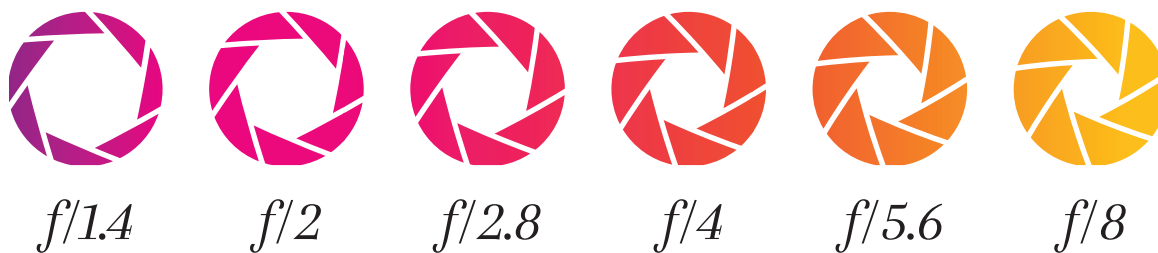

Figure 3: Lenses with lower (faster) f numbers provide more energy to the sensor and sharper images, but are larger in size than higher (slower) f number lenses.

## 6 DEPTH OF FIELD

Depth of field is determined by using the closest and the farthest objects that appear to be in focus. When a lens is focused in such a way that objects near the horizon are in focus, it is referred to as the infinity focus position. At this position, the closest object that is in focus is termed the hyperfocal distance. In visible photography, slower (larger) f number optics increase depth of field. IR camera lenses usually have higher f numbers, so depth of field is sacrificed for image quality.

The minimum object distance will determine how close someone can view an object by adjusting focus. For example, with a lens that has a hyperfocal distance of seventeen meters, it is possible to adjust focus to view an object as close as three meters, which would be considered the minimum object distance. The user can then expect everything closer than three meters to be out of focus.

Figure 4: Higher (slower) f numbers provide a larger depth of field, but are often not applicable for IR cameras as they require more energy/light.



## 7 PERFORMANCE, OR IMAGE QUALITY

There are three standard characteristics to consider for lens performance as it pertains to image quality.

- Modulation Transfer Function (MTF) Measurement: [According to Quality Magazine](#), “MTF is defined by the ability of a lens to reproduce lines (grids) with different spacings (spatial frequency in line pairs/mm). The more line pairs/mm that can be distinguished, the better the resolution of the lens.”
- Distortion: In wide-angle and fisheye lenses, images may have a barrel-type distortion, where the corners of the image are pulled in toward its center. FLIR compensates for distortion by means of the electronics and software used in a full imaging system. Most commercially-available digital image editing software can correct for distortion in a captured image. If a wide-angle lens with little distortion is required for a real-time application, it may be necessary to have a lens custom-designed.
- Spot Size: A typical focal plane array has tens of thousands of pixels, and the IR energy is imaged as a spot into each pixel or a group of pixels. If a lens is diffraction-limited, the spot that it makes within each pixel exceeds the IR camera’s ability to resolve the detail made by the lens.

A diffraction-limited lens is a rarity, though, because of manufacturing tolerances. A lens will resolve differently when used with different focal plane array configurations. The spot size may also perform differently with the center pixel (on-axis) than with the corner pixel (off-axis). A lens may exhibit diffraction-limited performance on-axis but fall short of this definition off-axis.

## 8 TRANSMISSION, OR IMAGE BRIGHTNESS

The transmission value of an IR camera lens is the level of energy that passes through the lens over the designed waveband. If a lens is said to have a transmission of 94 percent, this means that an average of 94 percent of the energy in the designed waveband entering the lens will exit the lens. The other 6 percent is either reflected or absorbed. The transmission is considered to be an average value because it will vary across the designated waveband.

Factors that contribute to transmission value are the optical materials, anti-reflection coatings, diffractive surfaces, and the number of optical components in a multi-element lens assembly. The details of these contributing factors are typically not available to the design team, so the value provided must be weighted along with performance to determine if the lens will work for a specific application.

!

It is important to note that a lens cannot simply be coated differently to work at the different wavebands. If a lens is designed to work in the MWIR, applying SWIR coatings will not allow it to work with a SWIR camera. This is because the optical prescription (e.g., materials, lens thickness, airspaces, and curvatures) is specific for the MWIR waveband.

## 9 ATHERMALIZATION

If a lens is designed to remain in focus over a wide temperature range, it is considered to be athermal. If an application requires the IR camera to be in an environment where the temperature fluctuates beyond the designed range, the image will need to be refocused. The extent of defocus will vary from lens to lens, and longer focal lengths are more susceptible to temperature change.

Passive athermalization is achieved by using different optical and mechanical materials with compensating thermal expansion coefficients. This method is most desirable for systems where size and weight are a factor. This is also the most cost-effective approach for small systems. Active athermalization is achieved by electrical means, with the use of a sensor that enables a motorized focus movement when temperature changes. This method makes the most sense for larger systems. The motor and electronics required for active athermalization will weigh less—and cost significantly less—than adding the necessary optical elements for passive athermalization.



## 10 MOUNT

Proper mounting is critical to ensure that the lens is in position for optimal performance. The three most common methods for interfacing the lens with the camera are:

**FLANGE:** A flange-mounted lens is mated to the camera by matching a bolt-hole pattern on both the lens flange and the camera housing. It is held in place with screws. This is the method used if a tight seal is required, or if the lens is permanently affixed to the camera. This also allows control of the lens orientation when mounted to the camera.

**THREADED:** The threaded interface is a low-cost approach, with the C mount being a commonly used thread interface. There is no control to lens orientation when using a threaded interface.

**BAYONET:** The bayonet style (or twist-lock) is the most convenient method, locking the lens into place with a simple twist and removing it by releasing a pin. The lens is affixed by registering it in proper orientation with the IR camera body and then twisting it 45° to 90° until it locks in place. This configuration is a more costly option. It also does not allow for precise alignment between the optical center line of the lens and focal plane array.



## 11 DEVELOPMENT AND PRODUCTION SCHEDULE

As new IR cameras are produced, and new applications emerge, new lenses must be developed. Quite often these lenses are custom, as they are specific to the application. Depending on the complexity of the lens to be developed, the timeline could be three to six months or longer. There are three primary phases to this development: engineering, manufacturing, and testing.

In the engineering phase, the design is developed from scratch. Depending on the use case, design may also include development of the specification. Case in point, the engineering involved in a zoom lens for an armored vehicle will be much more involved than a single FOV lens to be used in a laboratory. A simple lens may take three to four weeks in engineering, whereas a complex zoom lens may take eight to twelve weeks.

Manufacturing will also vary with complexity. A driving factor will be the optical materials required and the waveband for the anti-reflection coatings. If the materials are common and the coatings are standard, this phase may take only ten to twelve weeks. If materials are hard to get, and if coatings must be developed, this phase could take twelve to sixteen weeks. Mechanical components and electrical components should not drive schedule unless there is unusual customization.

The testing phase is highly dependent on the application. For a simple system that will be used in a lab environment, testing may be done within a couple days. If extensive optical testing is required for a multi-FOV or zoom lens, expect at least two weeks. Environmental stress screening (ESS) will also add time, if required. Basic thermal cycling and vibration testing can add a week to the timeline, but if extensive ESS is required due to the lens being used in a rugged environment, expect another two to three weeks.

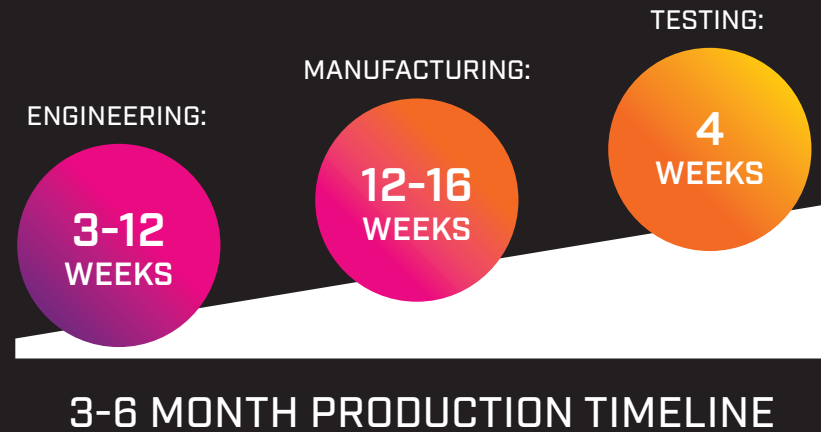

Figure 5: Depending on the lens complexity, production can take three to six months or longer.

## 12 COST

Optical materials and complexity are the biggest factors in IR lens costs. The two most common optical materials used in IR lenses are Silicon and Germanium. Silicon is much less expensive than Germanium, but that does not always correlate directly with production costs. In fact, the inverse is the case with LWIR cameras (i.e., uncooled microbolometers). They use Germanium as the primary lens material, as the high volume of LWIR systems allows for cost savings. Significant development has also gone into chalcogenide materials, which can be a lower cost option to Germanium when applicable.

Conversely, MWIR cameras tend to be more expensive even though Silicon is the primary optical material used for MWIR optics. Complexity (zoom or multifield) or the lower volume drive costs up for MWIR cameras.

# SUMMARY

Lens selection is essential to the development of any thermal imaging solution. It impacts cost, production time, and, most importantly, how the solution will perform—from its FOV to its control to its wavelength. Working with an end-to-end partner such as FLIR Systems that designs all elements of a thermal imaging camera, including the lenses, will help streamline innovation, design, and production.

Learn more at [www.FLIR.com/opticalsystems](http://www.FLIR.com/opticalsystems)



Learn more at [www.FLIR.com/opticalsystems](http://www.FLIR.com/opticalsystems)

*Images for illustrative purposes only. ©2019 FLIR Systems, Inc.*

19-2418-OEM-Lens Configuration Guidebook  
UPDATED: 10/25/19



The World's **Sixth Sense**®